

Fontaine® Fifth Wheel Custom Duty

Instructions



- Installation instructions
- Pre-service procedures
- Operating instructions
- Inspection & maintenance procedures
- Warranty

FOR YOUR SAFETY USE ONLY GENUINE FONTAINE SERVICE PARTS. USING PARTS THAT DO NOT MEET FONTAINE SPECIFICATIONS WILL VOID WARRANTY.

Read before mounting or operating fifth wheel.

After fifth wheel is installed these important instructions must be permanently retained in the tractor glove box.

WARNING: Failure to follow these instructions could cause a hazardous operating condition.



Fontaine® Fifth Wheel handbook

For over 60 years, Fontaine has been passing customer performance tests by building fifth wheels with innovative technology, uncompromising quality, and features designed to ensure cost-efficient performance.

This handbook provides instructions and recommended procedures for optimum performance from your new Fontaine Custom Duty fifth wheel. Included are: installation instructions, pre-service procedures, operating instructions, inspection and maintenance procedures, and warranty information. **keep this handbook in the tractor glove box after your fifth wheel has been installed.**

If you have any questions concerning your new fifth wheel, our Customer Service Group is available to help you. (800) 874-9780.

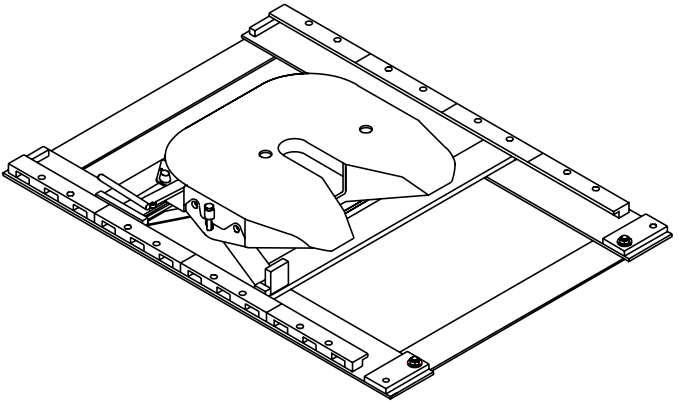

For sales and service locations or for additional copies of this handbook go to our web site at www.fifthwheel.com.

Section I – Installation instructions	
General mounting instructions.....	4-5
Section II – Pre-service procedures	
Fasteners	6
Lubrication	7-8
Operation	8-9
Wedge stop rod setting	9
Section III – Operating instructions.....	10-14
Section IV – Inspection and maintenance procedures.....	15
Section V – Custom Duty limited warranty	16-17

Section I – Installation instructions

General mounting instructions

1. **Do not** modify and/or customize any fifth wheel or mounting assembly. Modifying or welding to the product will void product warranty. Only Fontaine authorized procedures are acceptable. Welding must be performed by an AWS certified welder.
2. Installation shall be in accordance with DOT regulations, state and local ordinances, SAE and TMC practices and standards, and tractor manufacturers' recommendations.
3. All fifth wheels shall be located so that the tractor and trailer will maintain clearance at all times. On sliding fifth wheels, it may be necessary to "block out" forward locations.
4. All mounting fasteners must be a minimum of:
 - 5/8" diameter - grade 8 bolts
 - 5/8" diameter - grade C lock nuts
 - 5/8" diameter - hardened flat washers
5. All mounting holes shall be drilled, not burned. All edges shall be ground smooth to prevent point loading.
6. When required to clear obstructions (such as spring hangers) cutouts shall be smooth and straight with a minimum radius of 1". No sharp corners are permitted and all edges shall be ground smooth. A minimum of two bolts is recommended beyond a cutout.
7. Do not restrict normal rock of fifth wheel. This could create a hazardous operating condition.
8. All fifth wheels subjected to weather abuse must be thoroughly cleaned, inspected, and lubricated prior to installation.

Installation instructions

9. Fifth wheels with sliding or fixed mounts should be mounted in the proper orientation relative to the tractor (See figure 1).

Do not mount the fifth wheel upside down or backwards.

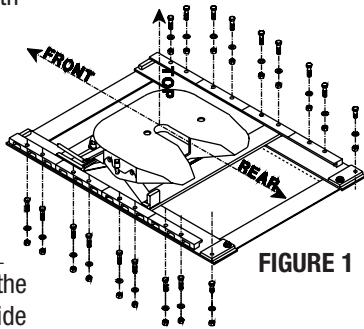

FIGURE 1

10. The trailer that is attached to the fifth wheel should impose a consistent vertical load. Repeated negative loading (trying to pull the fifth wheel off of the brackets with the king pin) is not allowed. A **minimum** vertical static load applied to the fifth wheel through the trailer is 10% of the gross trailer weight. See the load rating for the specific fifth wheel for maximum vertical load values.
11. **Do not** center load the fifth wheel. The vertical load should be distributed over the entire surface of the fifth wheel.

Section II – Pre-service procedures

A. Fasteners

Make sure all nuts and bolts are in place and properly tightened.

Check all welds for cracks, breaks or separation.

Check to see if both bracket pins are in place and secured by retainer pins and cotter pins.

See figure 2 below.

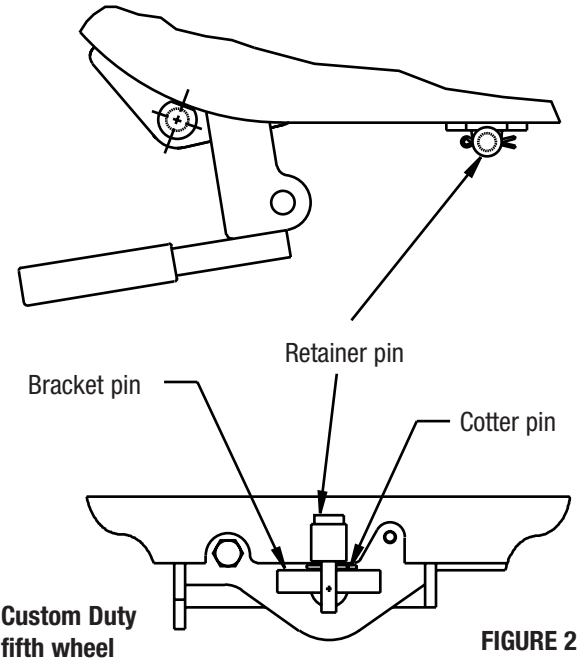

B. Lubrication

1. Tilt the top plate forward (front of the fifth wheel down) and apply grease to each bearing area through the zerk fitting each side of the top plate just to the front of the bracket pins. Continue to apply grease until it is coming out of the back of the bearing. It may be necessary to raise the rear of the fifth wheel with a pry bar to open up the pocket and allow the grease to flow through. Periodically remove the fifth wheel to clean old grease from the bracket grease channels to help insure even distribution of fresh grease. A substantial amount of grease may be required initially to fill the reservoir. Tilt the wheel to the rear (rear of the wheel down) and repeat the procedure. Rock the top plate back and forth several times to spread the grease over the bearing surface.

Inspect the trailer kingpin plate and top surface of the fifth wheel to make sure each is properly greased. A liberal coating of grease should be applied to the complete surfaces of both the trailer kingpin plate and the top surface of the fifth wheel. A paddle or brush will make this job easier.

Do not use a lube plate (high density polyethylene) on top of the fifth wheel or on the kingpin in lieu of grease without prior approval by Fontaine Fifth Wheel. The additional thickness of this material can prevent the proper operation of the fifth wheel and can cause a dangerous condition.

2. Lubricate the fifth wheel prior to opening and closing. Referring to figures 3 & 4 on next page, grease the jaw and wedge on top and bottom. Separate the jaw and wedge with a large screwdriver and distribute the grease along the full length of the jaw and wedge mating surfaces. Open and close the fifth wheel several times to further distribute the grease.

Lightly oil other moving parts in the fifth wheel.

Fontaine® Fifth Wheel handbook

3. For sliding fifth wheels, lightly oil the locking mechanism. Operate the mechanism several times to ensure it is functioning properly.

FIGURE 3

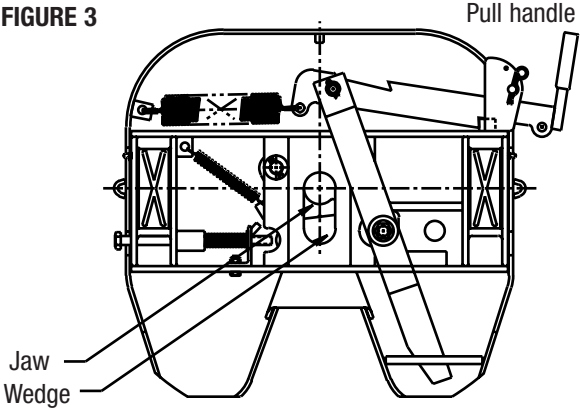
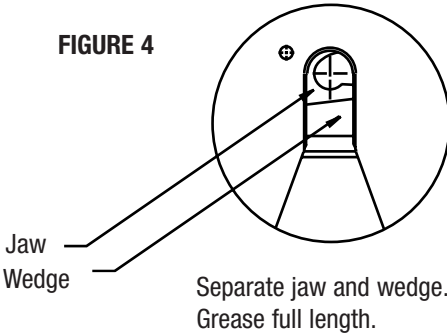

FIGURE 4



C. Operation

1. Fontaine's Custom Duty fifth wheel opens by removing the secondary safety lock pin, moving the pull handle slightly forward and pulling straight out until maximum opening stroke is achieved. At this point, the pull handle should again be moved slightly forward till the handle cut out sets up on the fifth wheel skirt.

Pre-service procedures

2. Close the locking mechanism using a test kingpin or 2" diameter pipe. Repeat several times making sure that all moving parts have adequate lubrication.
3. The pull handle grip should always be free of grease or any substance which could prevent a firm grip causing the handle to slip possibly resulting in injury.

D. Wedge stop rod setting

Close the fifth wheel on a standard 2" kingpin or a 2" diameter shaft inserted vertically. Push on the wedge stop rod. (Extends from the side of the top plate and looks like the head of a bolt.) It should move in 1/4" with hand pressure, then spring back out. To obtain a proper setting, turn the wedge stop rod clockwise to reduce the dimension and counter-clockwise to increase it. Adjust until the free travel is 1/4" (See figure 5). This will ensure that the automatic slack adjustment feature of the Fontaine Fifth Wheel is functioning properly.

This wedge stop rod can also be used to release a tight wedge (hard to open) by tapping the rod with a hammer to release the wedge.

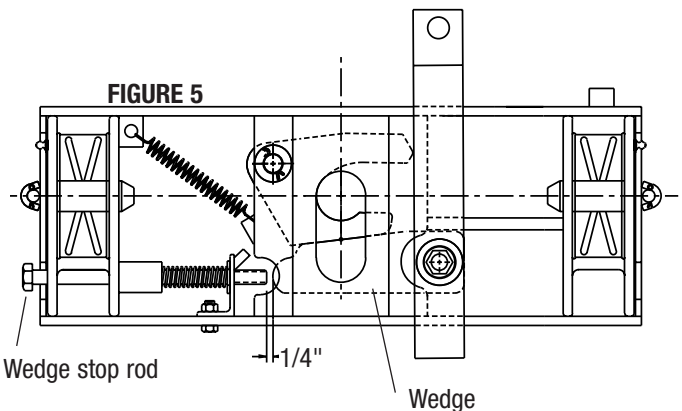

Section III – Operating instructions

Coupling procedure:

1. Prior to coupling, inspect the fifth wheel to ensure a proper operation.
 - Examine the mounting assembly for securely fastened bolts, cracked welds or material separation.
 - Tilt the fifth wheel up and down to make sure that it moves freely. Rest the fifth wheel in the proper position by tilting it to the rear of the tractor and resting it on the stops.
 - Check the top surface the fifth wheel for a liberal coating of grease.
 - If the tractor is equipped with an air sliding fifth wheel, actuate the air cylinder and check for air leaks. **WARNING: AIR CYLINDER SHOULD NOT BE DISASSEMBLED AS CONTENTS ARE UNDER SPRING LOAD.**
 - The fifth wheel should be in an unlocked position. When unlocked, the handle should be extended and the tips of the jaw and wedge visible (see Ffigure 6). **DO NOT TRY TO COUPLE TO A CLOSED FIFTH WHEEL.**

FIGURE 6

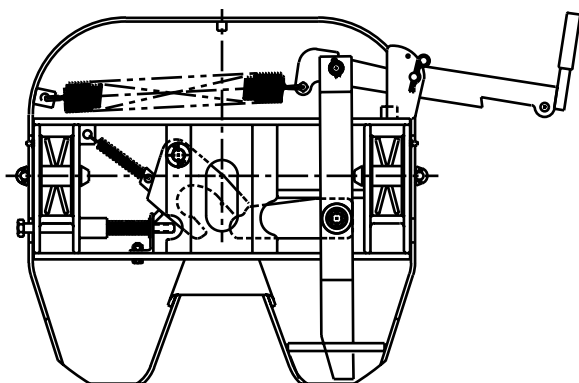

Operating instructions

2. The trailer kingpin should also be inspected prior to coupling. The kingpin plate should be fully reinforced and of sufficient size to completely cover the fifth wheel. If the kingpin plate is too narrow, the uncovered portion of the fifth wheel will collect dirt and foreign matter. This material may work into the fifth wheel locking mechanism, causing wear and difficulty uncoupling. This material can also cause galling of the fifth wheel and/or kingpin plate.

If the trailer kingpin plate is not fully reinforced, distortion can result causing:

- Non-uniform loading
- Variation in kingpin length
- Cutting and galling of the fifth wheel or kingpin plate

If the trailer kingpin plate is distorted enough to cause any of the conditions listed above, we recommend that a new plate be installed.

The trailer kingpin plate must be properly greased.

Fontaine Fifth Wheels are designed and manufactured for use with all trailer kingpins that conform to SAE specifications, SAE J700, February 1993 and subject to the wear limits of SAE J2228, July 1993. These specifications cover SAE 2" kingpins only.

The SAE standard kingpin can be checked using the dimensions given in figure 7 (next page).

FIGURE 13 SAE standard kingpin (SAE J700, FEB 93)

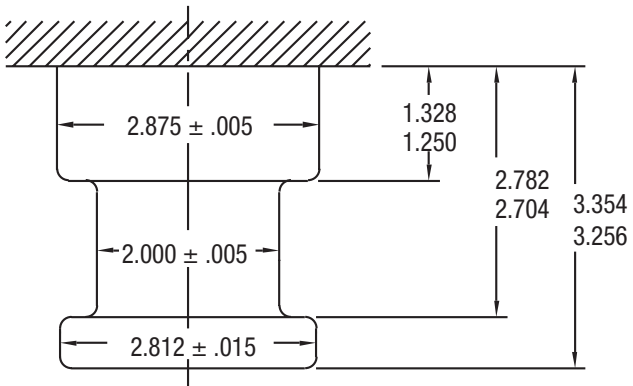

3. Proper tractor/trailer alignment is critical to obtain a secure coupling and to avoid equipment damage.

Set the trailer brakes and raise the trailer to the proper height by extending the landing legs. If the trailer is positioned too high, the kingpin may jump the fifth wheel throat and locking mechanism altogether. Resulting damage may include: scoring the fifth wheel, bending the handle thus preventing the fifth wheel from properly locking to the kingpin, bending the kingpin, and other significant damage to the tractor or trailer.

Coupling should not be attempted if the trailer is too low. Costly damage may be incurred to the trailer, the kingpin, the kingpin plate, the fifth wheel, and the entire tractor drivetrain.

4. To couple the fifth wheel to the kingpin, be sure the fifth wheel is positioned so that it tilts down at the rear and is resting on the stops.

Align the kingpin with the throat of the fifth wheel and ease the tractor toward the trailer. The trailer should strike the fifth wheel just at the top of the approach ramps. The fifth wheel will level with the kingpin plate and the kingpin should slide up the fifth wheel throat.

Operating instructions

Coupling is complete when the fifth wheel locking mechanism snaps closed behind the kingpin and the lock pin is properly installed.

Verify secure coupling with a "tug test," by easing the tractor forward to feel resistance of the load. If the coupling feels secure, visually inspect the fifth wheel. **The jaw and wedge must be locked in place behind the kingpin and the pull handle must be fully retracted and secured in place using the secondary lock pin.**

5. To position an air sliding fifth wheel, set the trailer brakes, unlock the cab control air valve and allow the air cylinder to retract the locking wedges. Ease the tractor forward or backward to move the fifth wheel to the desired position and lock the air valve. **Note: The fifth wheel must be in the locked position when changing slide positions.**

After the fifth wheel is properly positioned, inspect the locking wedges to ensure that they are fully engaged in the slide rail pockets.

Under no circumstances should a sliding fifth wheel be re-positioned while the tractor and trailer are in motion.

Do not attempt to slide the fifth wheel until all persons are clear of the vehicle.

Uncoupling procedure:

1. Prior to uncoupling, set the trailer parking brakes. Back the tractor gently but tightly against the trailer before setting the tractor parking brake. This will help relieve pressure from the fifth wheel locking mechanism.

IF THE TRUCK IS EQUIPPED WITH AIR RIDE SUSPENSION, DO NOT DUMP THE AIR BEFORE OPENING THE FIFTH WHEEL. DOING SO MAY CAUSE A HARD TO OPEN SITUATION.

2. Block the trailer wheels. If poor ground conditions exist, you may have to provide a base for the trailer landing gear.
 - Spring suspension: lower landing gear until it contacts the ground. Give a few extra turns in low gear. **DO NOT** lift the trailer off of the fifth wheel.
 - Air ride suspension: lower landing gear until it contacts the ground. Add one additional turn. **DO NOT** raise the trailer off of the fifth wheel.
3. Disconnect the air and electrical lines.
4. Remove the secondary lock pin and open the fifth wheel.
5. Pull out slowly from under the trailer. Let the trailer slide down the fifth wheel approach ramps. This will allow the air ride suspensions to adjust to unloaded height. **CAUTION: GOING TO QUICKLY WILL CAUSE THE SUSPENSION TO BOUNCE, POSSIBLY DAMAGING THE TRAILER, TRACTOR FRAME RAILS OR SUSPENSION AIR BAGS.**

Section IV – Inspection and maintenance procedures

Using a suitable solvent, degrease the fifth wheel and mounting brackets every 90 days or 30,000 miles, whichever comes first, and inspect for:

1. Cracks in the fifth wheel assembly, mounting brackets, and mounting parts.
2. Wear and/or damage to moving parts.
3. Correct placement of the secondary safety lock pin.
4. Loose nuts and bolts in the fifth wheel and in the mounting hardware.
5. Securely fastened and properly working springs.
6. Check to see if both bracket pins are in place and secured by retainer pins and cotter pins.

Lubrication

Follow the instructions provided in the Pre-service procedure on pages 7-8.

Special precautions must be taken during cold weather to ensure that the Fontaine Custom Duty locking mechanism operates freely. Ice and sludge can build up and lubricants become thick and binding at low temperatures.

When the temperature drops below freezing, Fontaine recommends the use of a cleaner or degreaser on the latching mechanism, making sure that the moving parts operate freely. This should be followed by an application of 90-weight oil to all moving parts. This procedure may also be necessary in operations where excessive road grime or grit is encountered.

The regular performance of the routine, "90-day/30,000 mile preventative maintenance procedure," is also recommended.

Section V – North America Custom Duty limited warranty

Fontaine International, Inc. ("Fontaine") warrants each Custom Duty model CD700 fifth wheel sold in North America on or after January 1, 2002, to be free from defects in material and workmanship for two years from the date of sale.

This warranty covers failures in the material and workmanship but does not cover failures due to:

1. Use in loads that are beyond federal, state and provincial highway limits or in special overweight load permits.
2. Improper installation of the fifth wheel.
3. Normal wear.
4. Accident.
5. Improper application (see the Fontaine application guide for additional information).
6. Misuse, alteration or negligence.
7. Failure to properly maintain the fifth wheel.
8. Inadequate repairs or alterations that, in Fontaine's judgment, adversely affect the fifth wheel's performance or reliability.

Fontaine cannot guarantee the service life of any fifth wheel since service life can vary with the application, usage, maintenance, environment, and other factors beyond Fontaine's control.

Authorization from Fontaine must be obtained before replacing or returning any part under this Limited Warranty. **All request for reimbursement must be submitted within 45 days of the repair.**

Limited Warranty

If the fifth wheel does not perform as warranted in this Limited Warranty or if there is any defect in material and workmanship covered by this Limited Warranty, Fontaine will, at its option, provide buyer with parts or reimburse buyer for parts at its reasonable acquisition cost, up to the amount of the original suggested list price. All labor costs are excluded. Fontaine may require the unit or part to be returned to Fontaine's factory or a Fontaine authorized representative for evaluation. All freight to and from Fontaine or a Fontaine authorized representative must be prepaid by buyer.

This is Fontaine's only warranty for the Custom Duty fifth wheel. Fontaine makes no other warranty of any kind, expressed or implied. All implied warranties or merchantability and/or fitness for a particular purpose are hereby disclaimed by Fontaine and excluded. This Limited Warranty may not be changed except in writing by an authorized officer of Fontaine. Any action for any alleged breach of this Limited Warranty must be commenced within one year after such alleged breach occurred or shall be forever barred.

The remedies stated above shall be exclusive for any and all claims by the original user, or anybody claiming through the original user, against Fontaine, whether based on contract, negligence, tort, or any other theory. **In no event shall Fontaine be liable for any incidental or consequential damages, losses, or expenses.**

This Limited Warranty gives buyer specific legal rights, and buyer may also have other rights, which may vary depending on the state, province or country where the truck is registered.

Note: This warranty is subject to revision without notice. See the Custom Duty Warranty Certificate LT-074.

**For sales and service locations
or for additional copies of this
handbook go to our web site at
www.fifthwheel.com.**

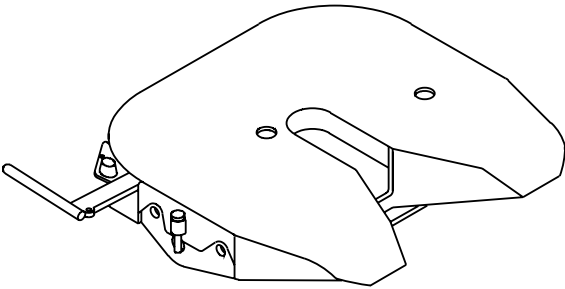

**DVDS are
available free of charge with
instructions for fifth wheel
maintenance, driver use of the
fifth wheel and driver coupling/
uncoupling instructions.**

**Please contact Customer
Services at
1-800-874-9780 to order these
tapes or check out our web site
at www.fifthwheel.com.**



Fontaine Fifth Wheel
7574 Commerce Circle • Trussville, AL 35173 USA
800.874.9780 • Fax 205.655.9982
www.fifthwheel.com